



A GPS and GSM-Based Rail Crack Detection System

Usha. G , Kiran P V , Gita Reshmi

Assoc. Prof & HOD, Asst. Professor, Asst. Professor
ushagonal645@gmail.com , pv.kiran1977@gmail.com , gita.v.patil@gmail.com
Department of ECE, Proudhadivaraya Institute of Technology, Abheraj Baldota Rd, Indiranagar, Hosapete,
Karnataka-583225

ABSTRACT

The Indian Railroad is among the world's largest rail networks. The Indian Railroads have come a long way, yet sometimes accidents still happen because of track defects. In response to this serious issue, we have developed a monitoring gadget that, using an Arduino UNO, can identify a track crack and communicate with a GSM and GPS module to send an SMS. Making ensuring everyone and everything on board is safe is our first priority. Utilising an Arduino microcontroller, the apparatus parses information gathered from several sensors installed along the rail lines. The sensors pick up on the fissures, and the microcontroller processes the data. After that, it notifies the proper authorities about the danger by contacting them. The alarm system sends the location of any detected cracks by SMS using the GPS and GSM module. You may see the warning on your screen in the form of an alarm or a message. Because of its low cost and ease of implementation, the Railway Crack Detection system that utilises Arduino is a practical option for railroads all over the globe.

INTRODUCTION

In today's world, transport, being one of the biggest drainers of energy, its sustainability and safety are issues of importance. This is the fourth largest railway network in the world. The Rail transport is growing at a rapid pace in India. It is one of the major modes of transport but still our facilities are not that accurate, safer as compared to international standards. A survey on the internet states that about 60% of all the rail accidents is due to derailments, recent measurements shows that about 90% are due to cracks on the rails. Hence, it is not safer for Human Life. This needs to be at the utmost

attention. This is need to be at the utmost attention. These goes unnoticed and the properly maintenance of tracks is not done. This model says about a proposed proto type of testing train for detecting obstacles and crack.. To overcome this disadvantage, here proximity sensor is used, which will detect the crack accurately. This project discusses a Railway track crack detection using sensors and is a dynamic approach which combines the use of GPS tracking system to send alert messages and the geographical coordinate of location. Arduino Microcontrollers used to control and coordinate the activities of this device. The existing system is slow, tedious and time consuming. This system has GSM and GPS module which will give the real time location or coordinates in the form of Short Message Service(SMS) to the nearest railway station .To identify defects or symptoms of digital images of track elements the Railway service presently uses machine vision technology and for analysis of images uses custom algorithms. These machines are larger in size and are manually operated by a person. Proposed system is small and efficient to use.

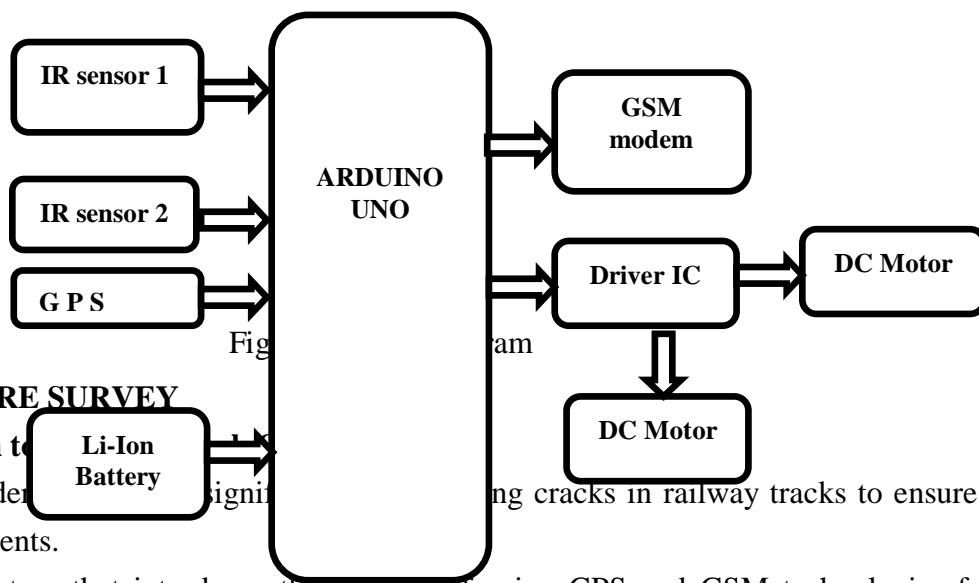

LITERATURE SURVEY

Introduction to

Begin by understanding the significance of detecting cracks in railway tracks to ensure safety and prevent accidents.

Explore literature that introduces the concept of using GPS and GSM technologies for real-time monitoring of railway tracks.

Existing Crack Detection Techniques:

Investigate research papers and articles that discuss traditional methods for detecting cracks in railway tracks, such as visual inspection, ultrasonic testing, and eddy current testing.

Look for studies that evaluate the limitations and challenges of these methods, including their labor-intensive nature and limitations in coverage and accuracy.

Role of GPS and GSM in Crack Detection:

Review literature on how GPS and GSM technologies can be integrated into crack detection systems for railways.

Explore studies that discuss the advantages of using GPS for precise location tracking and GSM for

real-time communication of detection results and alerts.

Sensor Technologies for Crack Detection:

Examine research papers and articles that explore sensor technologies used in conjunction with GPS and GSM for crack detection.

Look for studies that discuss the deployment of accelerometers, strain gauges, acoustic sensors, or optical sensors to detect changes in track conditions indicative of cracks.

Data Fusion and Analysis:

Investigate literature on how data from GPS, GSM, and crack detection sensors are fused and analyzed to detect and classify cracks in railway tracks. Explore studies that discuss the development of algorithms for feature extraction, pattern recognition, and anomaly detection to identify potential crack locations.

PROPOSED SYSTEM

In proposed system crack in the tracks is detected by means of sensor and Arduino microcontroller, measuring distance for two railroad. In this project we use ultrasonic sensor to detect the crack. It uses to measure the distance between the two tracks. If any crack are occurred in the track means longitude and latitude coordinates of the place are to be sent to the nearest station or control room and IR sensor measured the distance between the two track if there is any small variance found the message which contains coordinates of that particular place will be sent to the nearest station or control room with the help of GPS and GSM module. This project is to be made in order to change the system of crack detection in railways which can be resulted out as not only costeffective but also with good accuracy and time saving facility

- a) Initially the tracks are being continuously monitored with the help of sensor, which is used to detect the crack in the tracks.
- b) This monitoring is done with the help of IR sensor in order to sense the minor changes also which can be quite difficult with other sensors.
- c) Whenever the crack gets detected with the help of IR sensor it passes the alert of crack found to the Arduino microcontroller.
- d) The Arduino microcontroller will perform the 5process assigned to it accordingly.

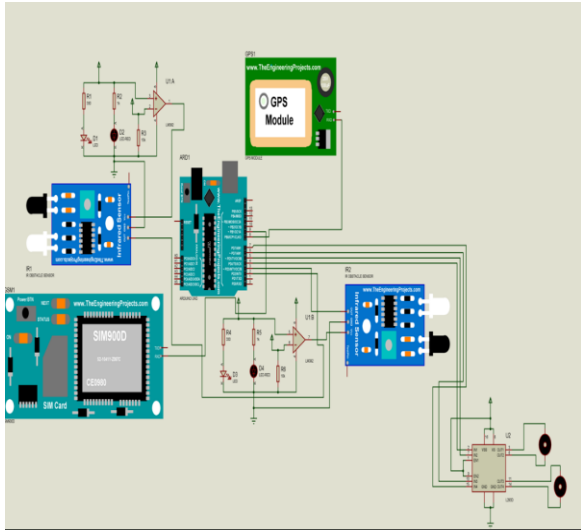

Figure.2 Stimulation Diagram

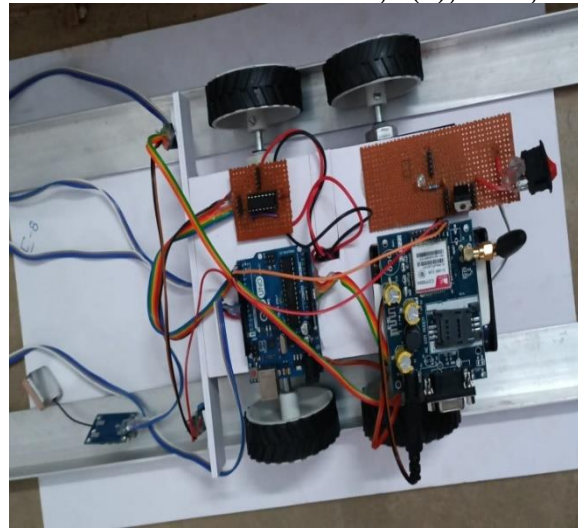

Figure.3 Top View of the device

RESULTS



Figure.5 Top view of device in ON state

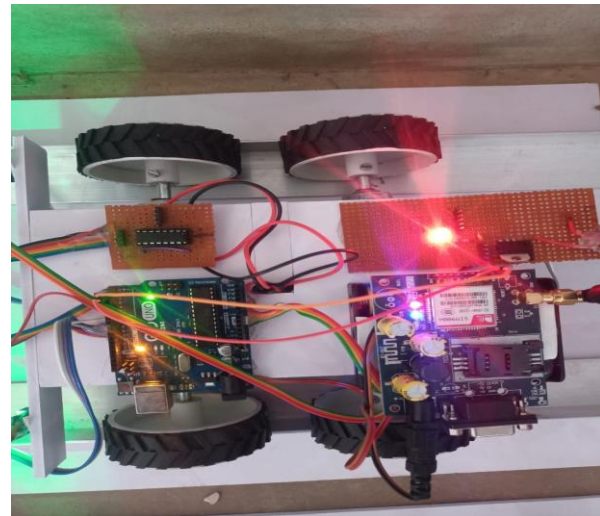

Figure.4 Front View of device

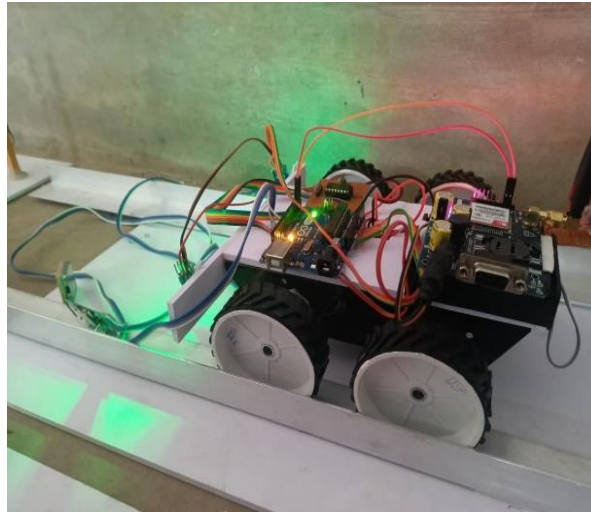

Figure.6 Device in ON state

CONCLUSION

Using an autonomous vehicle for railway track inspection and crack diagnosis will have a significant influence on track maintenance, ultimately helping to reduce the occurrence of train accidents. This vehicle is ideal for places where human inspectors would struggle to reach, such as in densely forested areas, deep inside coal mines, or on hilly terrain. When utilised for railway track inspection and crack detection, this vehicle's sensors will automatically send an SMS to a pre-defined phone number if they detect any fracture or deformation. The error-free maintenance and monitoring of railway track conditions greatly aids in keeping the tracks in excellent repair and significantly reduces the likelihood of train accidents. Autonomous vehicles built for railway track crack detection may help prevent train accidents by locating and reporting track problems like cracks. A mode of transportation that may be used by those residing in outlying regions. Current methods are both inefficient and costly, according to the research. In addition to fixing these issues, the proposed technique makes rail fracture detection more accurate. As far as our country's railroads are concerned, this is the most cost-effective strategy to reduce accident statistics. Consequently, it's feasible to prevent the loss of economic value and the lives of travellers. Finding cracks in concrete also becomes more easier and cheaper using this method.

FUTURE SCOPE

The automated vehicle robot can be given a faster speed, but more work needs to be done in this area. In addition, improvements can be made to provide a more precise location for the fault's origin. To increase the effectiveness of this system, the robot can also be made large enough that, using its weight, the track's stress and strain parameters can be evaluated. If you want to offer robust connectivity at a low input cost, you can also add a Zigbee module for a quick, short-distance inspection mechanism. A solar supply could be used to power it. Being environmentally friendly and generally

accessible, solar energy.

REFERENCE

- [1]. M. Kumar M., M. S. Murali, M. Saranya, S. Arun and R. P. Jayakrishnan, "A Survey on Crack Detection Technique in Railway Track," 2018 Conference on Emerging Devices and Smart Systems (ICEDSS), Tiruchengode, India, 2018, pp. 269-272, doi: 10.1109/ICEDSS.2018.8544319.
- [2]. J. N. L. A, L. Narayanan C, K. M. S, R. S and K. R. "Railway Track Crack and Key Detection Robot using IoT," 2022 International Conference on Edge Computing and Applications (ICECAA), Tamil nadu, India, 2022, pp. 623-628, doi: 10.1109/ICECAA55415.2022.9936435.
- [3]. B. S. Sathish, P. Ganesan, A. Ranganayakulu, S. S. Dola and S. J. M. Rao, "Advanced. Automatic Detection of Cracks in Railway Tracks," 2019 5th International Conference on Advanced Computing & Communication Systems (ICACCS), Coimbatore, India, 2019, pp. 98-101, doi: 10.1109/ICACCS.2019.8728451.
- [4]. A. A. Amusan and Y. K. Adebakin, "An Automatic Railway Level Crossing System with Crack Detection," 2022 5th Information Technology for Education and Development (ITED), Abuja, Nigeria, 2022, pp. 1-7, doi: 10.1109/ITED56637.2022.10051357.
- [5]. S. N. G. M. Iype, K. C. P, M. Sharon and S. Subhash, "Rail Track Defect Detection using Enhanced Method of Magnetic Flux Leakage Signal, 2021 International Conference on Design. Innovations for 3Cs Compute Communicate Control (ICDI3C), Bangalore, India, 2021, pp. 277- 280, doi: 10.1109/ICDI3C53598.2021.00062.
- [6]. W. Li, M. Zhang, Z. Shen, W. Hu and P. Li, "Track Crack Detection Method in Complex Environment," 2018 11th International Symposium on Computational Intelligence and Design (ISCID), Hangzhou, China, 2018, pp. 356-359, doi: 10.1109/ISCID.2018.00087.